

# ICON

---

PERFECT FOR EVERY NEED,  
VERSATILE IN EVERY SPACE





## “Craftsmanship and Sustainability”



### A BRAND YOU CAN COUNT ON

A kitchen is not just a workplace. It is a crucible for ideas, a space for relationships, where precision and efficiency acquire meaning when they culminate in memorable experiences.

Angelo Po has been reconciling functionality and beauty for 100 years, innovating solutions and design through a flow of inspirations generated by a sincere commitment to sustainability and an active dialogue with customers.

We view safeguarding health and safety as a fundamental principle and perform a constant series of strict checks on our production processes and systems on a daily basis. As a result, we guarantee not only unbeatable quality and safety but also outstanding performance in line with the sector's most demanding standards. Angelo Po is dedicated to the design of certified, energy-saving equipment specially developed to reduce consumption, improve energy efficiency and ensure impeccable hygiene in professional kitchens. We take special care over our products, making sure they always comply with the latest international standards and are tailored to the market's future needs. Our constant focus is on innovation and the development of environment-friendly solutions, optimising resources without ever compromising on quality.

# “The lay-out: made-to-measure project”



4

## DEDICATED DESIGN

Italian-made cooking ranges:  
design and innovation in perfect harmony.

With advice from highly experienced chefs, our designers work alongside customers, creating projects tailored to their needs and finding the best solution to maximise production while reducing waste.

Rapid, on-time shipments and deliveries, precision and efficiency during assembly and installation, meticulous on-site testing and continuous services everywhere in the world. A customer-oriented philosophy and practice that starts from the first contact and never stops. This deeply rooted culture of service has won us the respect of the market and our customers, who have always been our best ambassadors.



ANALYSIS



DESIGN



CONSTRUCTION



SUPPORT



AFTER-SALES  
SERVICE

MADE IN ITALY



5



“ Created for you,  
for all your needs ”

#### Commercial Catering.



Discover the versatility and performance of ICON, which adapts easily to all your menus. With its power and easy cleaning, it guarantees efficiency and authentic flavour in every dish, making your cooking range the fulcrum of your restaurant.

#### Trendy venues.



Innovate your venue with a versatile, powerful range, perfect for preparing creative, tasty dishes. With easy cleaning, you can focus on creating unique experiences for your customers, without wasting time.

#### Institutional Catering.



Guarantee quality meals efficiently with a range able to deliver large quantities of food on a continuous basis and designed to optimise flows and ensure operator comfort. The easy cleaning maximises speed in daily sanitisation procedures and minimises risks.

#### Luxury Hotels.



Enhance your luxury venue's excellence with a state-of-the-art, stylish, versatile, powerful cooking range. ICON will be at your service and every dish will be a culinary masterpiece, to impress and delight your guests.

# ICON

Line of modular cooking units  
70/90 cm deep



“The heart of your  
creative kitchen”

ICON has room for creativity and productivity and for the ideas and projects of cooks who want great results. ICON is versatile, tough, high-performing and reliable: it's designed for people like you, who work every day to deliver memorable culinary experiences.

“Embodying all  
Angelo Po’s  
experience”



Versatile 01

A truly complete, flexible system, for all catering contexts, available 70 or 90 cm deep, with a wide choice of base and top modules.

Powerful 02

This cooking range has everything a chef could desire: performance and productivity are maximised to enable great achievements even in small spaces.

Built to Last 03

Designed to last and to withstand even the toughest use, rugged and resistant inside and out. A real heavy-duty range!

Easy to Clean 04

The only range with certified HYGIENIC DESIGN, aiding cleanliness and food safety.

Pleasant to Use 05

Plenty of attention to the details of crucial importance for the chef’s efficiency and comfort.

Reliable 06

Finely crafted details, choice quality materials, reliability and safety are all intrinsic to the Angelo Po brand.

100% Customisable 07

Customisable in colour and choice of finishes, to create the perfect blend of style and user-friendliness.

Elegant and Functional 08

The functional design typical of Angelo Po, with strong lines ready to evolve to serve tomorrow’s needs yet well tuned to the style of today.

“ICON knows the value of space today”

ICON9000



ICON7000  
70 cm deep

ICON9000  
90 cm deep

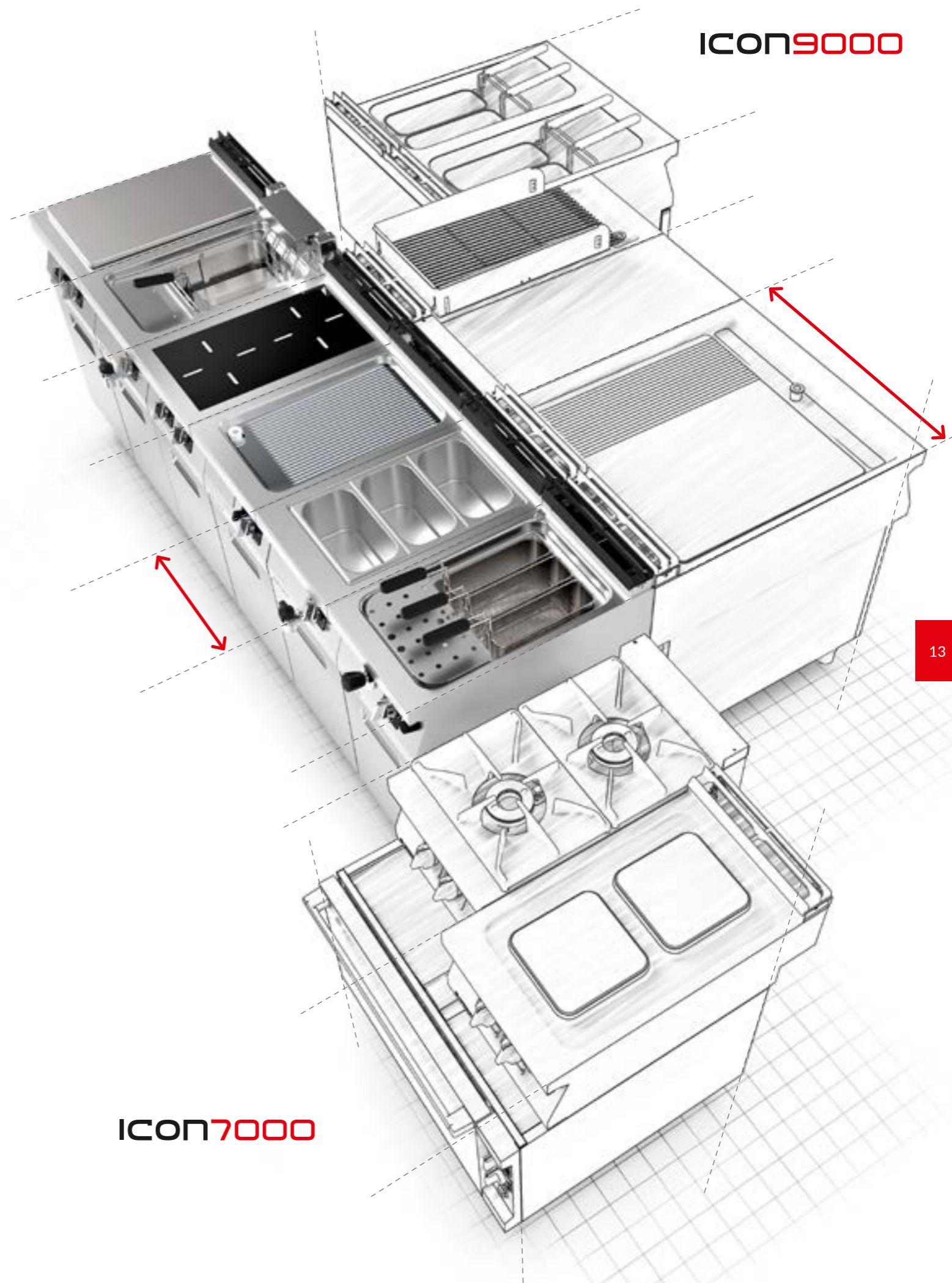

ICON7000

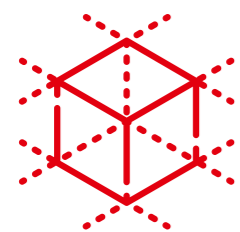

## VERSATILE DESIGN

The truly flexible system with infinite solutions for the tightest spaces, in all catering contexts.

Countless configuration options for a system with high potential: wide range of modules easily installed on existing work surfaces, assembled on floor-standing units, or for beam or bridge mounting, able to take multifunctional uprights and neutral, heated and refrigerated compartments. Modules both 70 cm and 90 cm deep are 40 cm wide, for perfect combination in back-to-back layouts.



“High performance for high-quality cooking”



10 kW



5 kW



XL



nanotechnologies



## UNBEATABLE PERFORMANCE: THE RANGE THAT EXCEEDS ALL EXPECTATIONS

Make the most of every centimetre available without sacrificing perfect cooking and easy cleaning.

The module width of 40 cm guarantees the highest productivity levels, which combine with high power outputs to guarantee excellent creations in double-quick times. Open burners with powers up to 10 kW, induction tops up to 5 kW, fryers, grills, pasta cookers and griddles with high-performance plates: the ideal ingredients for outstanding cooking results, repeatable and constant over time!

### NANOTECHNOLOGY GRILL

Cast-iron cooking grids with a nanotechnology surface treatment which improves run-off of fats and grease by up to 8%\*. What's more, in the gas version, the grid profile helps fat and grease drain off towards the front collection point. The grill, ceramic stone tiles and burner are easily, completely removable and are fully washable.

\* compared to previous model



## DESIGNED TO CONQUER TIME

Rugged and sturdy, resistant to corrosion and to daily use by the most demanding users, ICON is designed to last.

ICON also stands for quality and durability, a hallmark of Angelo Po. The structure is made of AISI 304 stainless steel and when 90 cm deep the one-piece worktop can be up to 3 mm thick: a robust and durable solution designed for those not prepared to settle for less. Performance and culinary perfection are guaranteed for small and large outputs. Contact surfaces are plastic-free, smoke exhaust flues and grids are in enamelled cast iron, and handles and doors are in press-formed steel. Internal components are highly durable. Characteristics that make ICON the heavy-duty cooking range built to do great things.



## CHOOSE THE ONE-PIECE WORKTOP OPTION

The perfect blend of elegance, strength and user-friendliness.

Opt for the one-piece worktop, which has no size limits and is made without joints or cracks, with a unique, scratch-resistant surface finish that retains its beauty over time. Moreover, the one-piece worktop reduces non-routine cleaning time, providing a real and immediate economic benefit.

“The toughness of a great heavy-duty range”



“The best aid for hygiene and safety”



## THE ONLY PRODUCTS ON THE MARKET WITH **CERTIFIED HYGIENIC DESIGN**

ICON's design and construction characteristics **simplify cleaning** and enable effective sanitisation at all times.

ICON is the only range with hygienic design certified by the independent external body CSQA: thanks to design and construction features such as lavish use of rounded zones, sloping surfaces, press-formed wells and adoption of low-roughness materials, easy cleaning, proper sanitisation and limited use of detergents are guaranteed, facilitating compliance with HACCP protocols. ICON9000 conforms to the IPX5 standard (water jet protection).

### H2 HYGIENIC COMPARTMENTS.

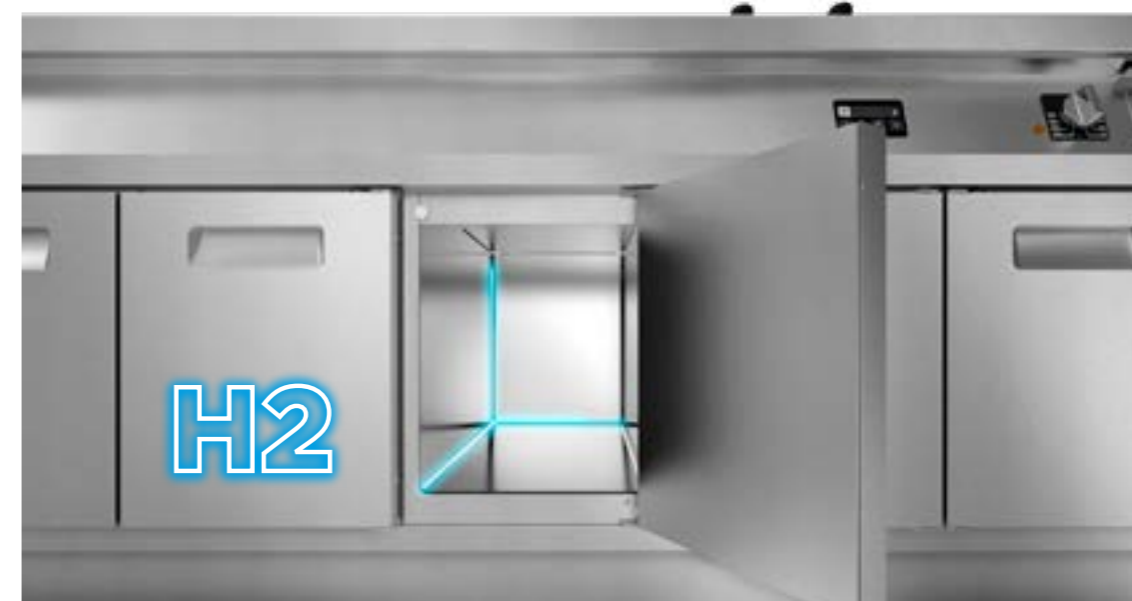

Shorter cleaning times and less use of chemical cleaning products.

Choose maximum hygiene for your kitchen. Choose H2 optional hygienic compartments, easy to clean because they have covered joints between bottom, back and sides.

“Everything within reach of the chef!”



20



## FLAWLESS ORGANISATION

More space and better ergonomics for maximum functionality.

The only modular cooking system that makes optimal use of space thanks to its incredibly modular composition: as well as conventional side-by-side modules, it includes multifunctional elements above and below the top, making your kitchen less cramped and more productive.

Extremely modular in both horizontal and vertical directions, thanks to its LEDs for ideal lighting of the top, Gastronorm trays which allow you to keep condiments within easy reach, and power sockets and water taps to simplify preparation.



21



“ Well-being in the kitchen has always been one of our key priorities ”



## CHEF COMFORT-PRO BORN TO BE ERGONOMIC

Not just safe but also designed for better working conditions, to reduce stress levels and improve well-being in the workplace.

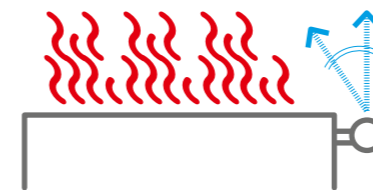

ICON features the innovative Chef Comfort-Pro system which creates an invisible barrier between the cooking zone and the chef. Chef Comfort-Pro reduces the heat given off by the appliance, creating a pleasanter working environment. At the same time it effectively drives fumes and unpleasant smells towards the hood, perfecting operation of the extraction system and preventing overheating of the environment, with the resulting energy wastage. Chef Comfort-Pro is position-adjustable and the air outflow can be regulated (3 speed settings) to modulate the flow to individual needs.



You can choose the colour that best suits your premises and customise the dashboard panel and doors to give the right touch of style. What's more, you also have a choice of worktops 70 or 90 cm deep, the type of aesthetic side terminals, traditional or H2 compartments, and standard or single dashboard panel. Our consultants are at your service to design your dream kitchen.

**COLOUR.**  
A touch of style



**H2 HYGIENIC COMPARTMENTS.**  
Maximum hygiene forever



**ONE-PIECE WORKTOP.**  
Without limits



“ Perfect Fusion ”

“ Can be customised  
as you wish ”



**COLORS**

Dashboard panel and doors in  
RAL colour of customer's choice

One-piece worktop, without joints or cracks,  
brushed finish with circular strokes

Single dashboard panel



Plinth

Large choice of under compartments:  
refrigerated, heated and neutral, also  
available with H2 hygienic finish

Installation on multi-module stand,  
assembly and packaging in a wooden crate

Welded side  
terminals

# “Bespoke offer proposals”

## INSTALLATION TYPES

- A** ON WHEELS
- B** ON FEET
- C** BRIDGE
- D** ON MULTI-MODULE STAND
- E** ON SUPPORT SURFACES
- F** SINGLE-SIDED OR DOUBLE-SIDED SUSPENDED BEAM INSTALLATIONS

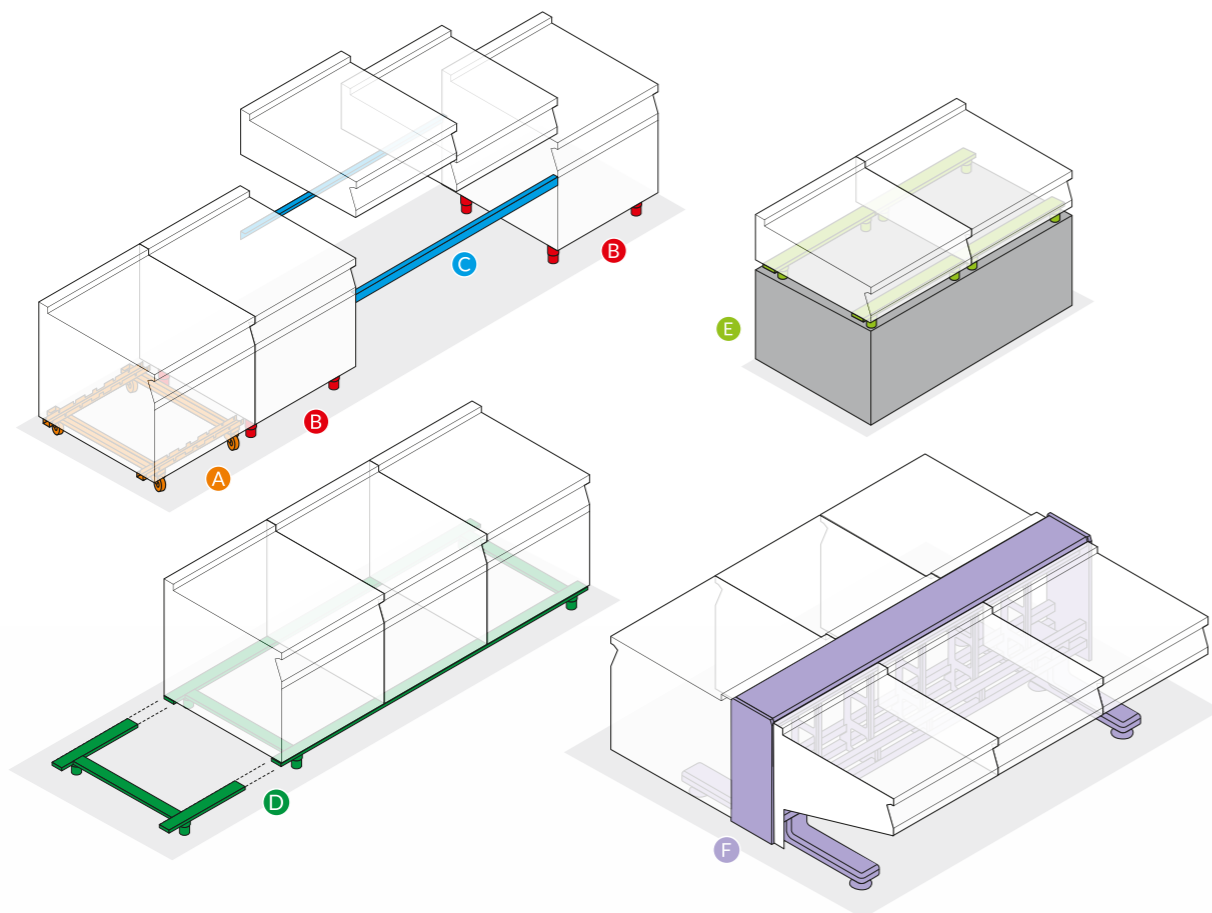

**GRIDDLE.**

With unbeatable performance



Extremely short heating times for superlative performance, even with frozen foods. Power output is always automatically, actively controlled and guarantees short recovery times and constant temperature.

**JOLLY-E OVEN.**

Versatility



The fan oven for installation underneath top version appliances, two of 40 or one of 80 cm. Thanks to the new CLIMA-PRO system, it stops steam from building up inside the chamber, for perfect gastronomic results.

**REFRIGERATED UNDER COMPARTMENTS.**

Kitchen refrigeration



All the cold storage a chef needs, in easy reach, thanks to the wide choice of refrigerator and freezer counter bottoms, with doors or drawers.

**COOKING-PRO**

High-performing and efficient



The COOKING-PRO system guarantees more rapid heating, extremely uniform cooking, better energy efficiency and higher performance, thanks to the special construction of the cooking plate with heating element embedded in an innovative multilayer material.

**EVEN-PRO**

Uniform, repeatable cooking



Uniform cooking and repeatable results are guaranteed by EVEN-PRO, a multilayer coating system used for electric bratt pan and griddle plates.

**INDUCTION TOPS.**

Adaptive power



Independent cooking zones of up to 7 kW each: quick and productive for the most demanding clientele.

**OPEN BURNERS.**

Unbeatable strength and power



Double-crown burners have power up to 10 kW for faster, more uniform cooking. Easy cleaning and durability, thanks to the cast-iron grids and press-formed well.

[www.angelopo.com](http://www.angelopo.com)

7900849-1



ANGELO PO Grandi Cucine SpA con socio unico  
41012 CARPI (MO) - ITALY - S/S Romana Sud, 90  
Tel. +39 059 639411 - [angelopo@angelopo.it](mailto:angelopo@angelopo.it)



A Berkshire Hathaway Company